

PLAN

NOTES:

1. ALL PRECAST REINFORCED CONCRETE MANHOLE SECTIONS SHALL COMPLY WITH ASTM C-478.
2. CEMENT SHALL BE TYPE II OR III, AIR ENTRAINED, WITH $f'_c=4,000$ psi AT 28 DAYS.
3. REINFORCEMENT SHALL BE GRADE 60 PER ASTM A-615.
4. 24" DIA CAST IRON FRAME AND COVER PER ASTM A-48, CLASS 30, FOR H-20 LOADING.
5. CAST IRON FRAME TO BE BOLTED TO MANHOLE WITH $\frac{5}{8}$ " ANCHOR BOLTS.
6. CASTING AND GRADE RINGS TO BE SEALED TO MANHOLE WITH WATERPROOF MORTAR OR PREFORMED PLASTIC SEALING COMPOUND.
7. ALL JOINTS SHALL BE SEALED WITH PREFORMED PLASTIC SEALING COMPOUND.
8. COAT MANHOLE EXTERIOR W/DAMP PROOFING (PROMASTIC 900 COAL TAR).
9. PRECAST CONCRETE GRADE ADJUSTMENT RINGS SHALL BE ONE PIECE (NO SEMI-CIRCULAR SECTIONS) AND SHALL HAVE A MINIMUM THICKNESS OF 2 INCHES.

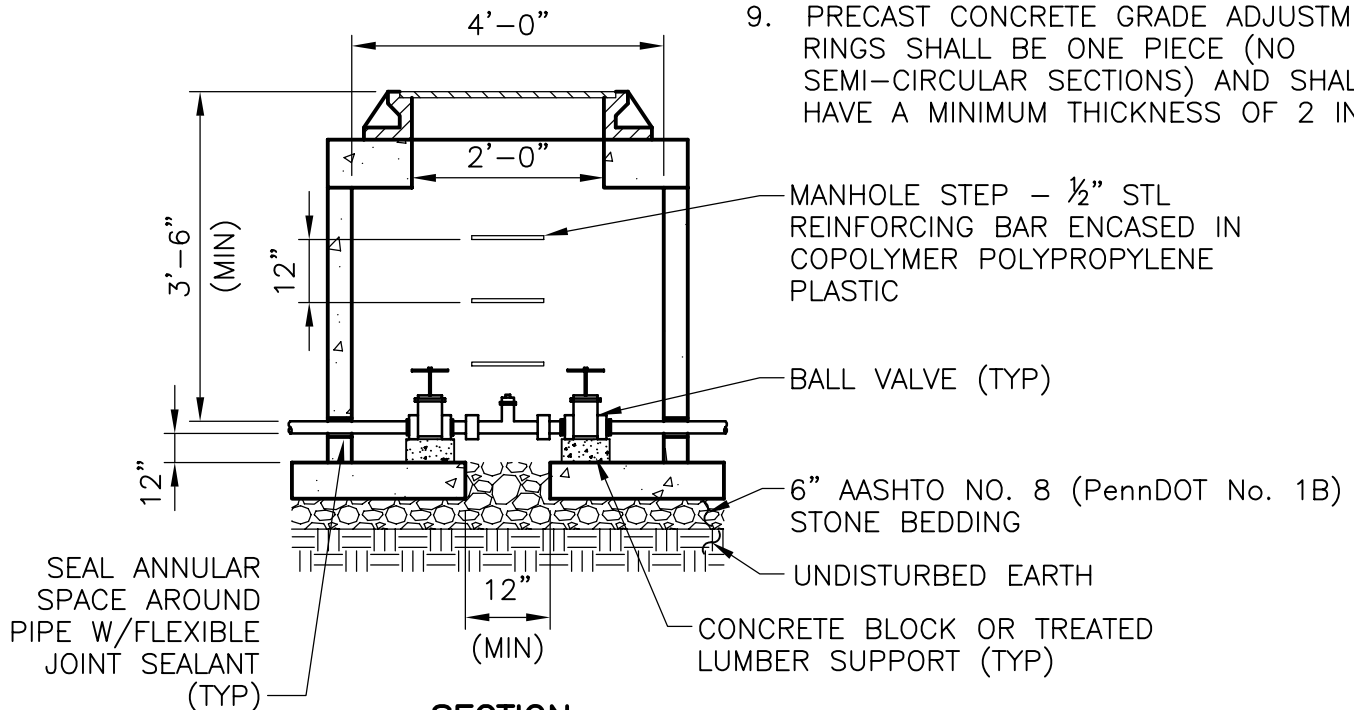

SECTION

LOW-PRESSURE SEWER VALVE AND CLEANOUT MANHOLE

DETAIL

NO SCALE

